

AT 3/4/6

Automatic PurePath™ To Your Speakers

The AT series of selectors, with automatic PurePath™ protection allows you the ease of choosing which rooms in your whole-house audio system are on or off from one convenient location. Automatic PurePath amplifier protection constantly processes how many speakers are selected and provides the purest possible path from the amplifier to the speaker.

Ultimate fidelity for critical listening can occur in any room at any time with the AT series of selectors. Simply select only the room you are in and the AT series automatically provides an absolutely pure, direct path to the speakers. As you engage more pairs of speakers, the AT series gradually inserts amplifier protection, while constantly striving to keep the maximum power flowing to your speakers. Only Audioplex AT series selectors automatically remove protection when it is unnecessary. This makes these unique selectors the only choice for those who love music enough that they demand control over any room

Installed next to your stereo, the AT series of switchers protects your amplifier and provides you with complete control over which rooms play.



The AT series of speaker selectors includes the AT-3, the AT-4 and the AT-6 accommodating three, four and six pairs of speakers respectively. The controls of the AT series allow you to play any combination of speakers

AUDIOPLEX®
TECHNOLOGY

TECHNICAL DETAILS

No Service Call Buttons

Unlike other manufacturers, the AT series does not have "protection" buttons that children or inexperienced users could accidentally press. Accidental deactivation of amplifier protection can devastate your equipment, requiring expensive service calls and repairs. Audioplex AT series provides automatic protection. No one can damage the audio system

Designed For Performance

The AT series are designed and engineered to have ruler flat-frequency response and ultra-low distortion. Audioplex delivers 20 to 20,000 Hz plus or minus 0.5 dB.

Proprietary ThermoTek™ (thermal overload protection)

The AT series is compatible with high powered receivers and amplifiers. If a

high-powered amplifier is overdriven, the distortion generated could quickly destroy the tweeters of your speakers. ThermoTek circuit protection shuts off the sound before your speakers or your components are damaged in the event of

Maximum Power Distribution

Only Audioplex selectors provide the maximum power to your speakers. All other designs suffer from excessive

protection syndrome disabling your systems potential by squandering up to 80% of your amplifier's power.

Perfectly Combines With PurePath™ Volume Controls

Combine the ultimate fidelity of the AT series with the innovation of PurePath volume controls. These unique volume controls provide you with one step, the PurePath step, that artfully provides a parallel bypass of the attenuator circuitry. Now when you critically listen to music

in any room, Audioplex can create an absolutely PurePath from your amplifier to the speakers. Audioplex manufactures a wide range of in-wall, behind-the-scene and component-style volume controls perfect for maintaining the ultimate fidelity of PurePath.

Two Zone Systems Gain One Touch To Global Music

If you own a surround-sound receiver and a stereo receiver, the AT series provides

one touch switchover for the whole house speaker system to access either receiver. This unique feature allows you to listen to music in the house, while someone else listens to DVD in the home theater. Yet, when you entertain, a single touch to your AT series provides you with the same music everywhere.

Lifetime Warranty

Audioplex provides a lifetime warranty, guaranteeing the performance and function of our switchers for the life of the original end user.

APPLICATION NOTES

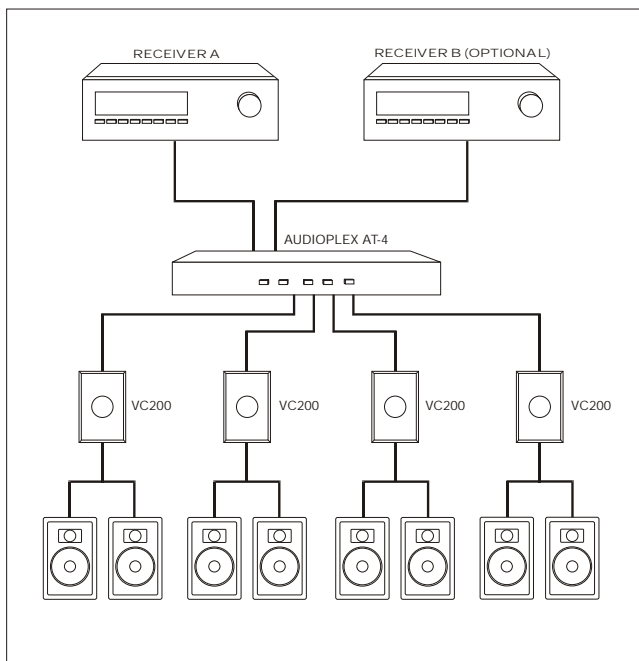

Wiring a AT-3/4/6 System

Three connections need to be made:

- 1) Connect speaker wire from the main speaker output of the amplifier/receiver to the amplifier inputs of the AT selector.
- 2) Connect speaker wire from the AT selector to the PurePath volume controls in each room.
- 3) Connect speaker wire from each of the PurePath volume controls to the speakers.

PurePath™ Volume Controls

Audioplex manufactures a wide range of PurePath volume controls that offer your system independent, local control of each room's speaker volume from an attractive shelf or flush mounted location.

SPECIFICATIONS

Power Handling:
Speaker/Amplifier Connectors:
Dimensions:

Suitable for use with amplifiers of up to 200 watts per channel.
Screw-type connectors capable of connecting 12 gauge wire.
AT-3/4 17"W x 1.75"H x 5"D / AT-6 17"W x 1.75"H x 6.25"D



AUDIOPLEX®

TECHNOLOGY

